

CLIMA HOSTELERÍA



- Product Code: EMP.1100

- Built in rinse aid dispenser.
- Drain pump.
- Total Power:3,2 kw.
- Programme options: 90o,-120o,-180o C seconds.
- 220 v operating system.
- 400x400 mm basket dimension.

Top

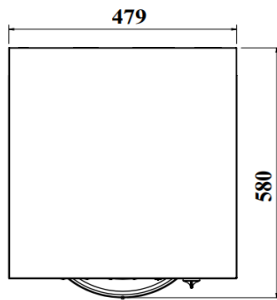

Side

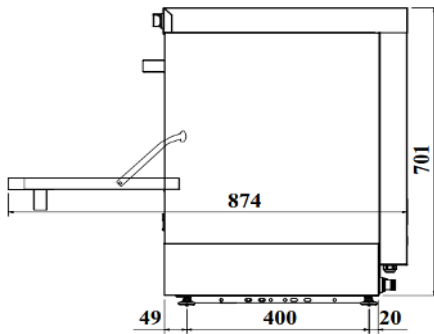

Back

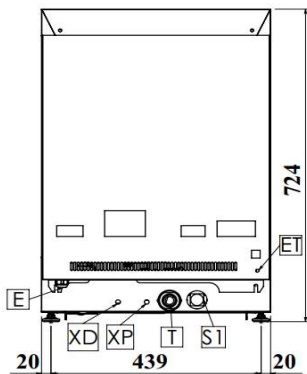

- ET - Grounding Screw
- E - Electric Inlet
- T - Water Drain
- S1 - Cold Water Inlet
- XD - Detergent pump outlet
- XP - Rinse pump outlet

Main Information

Length	480 mm
Depth	580 mm
Height	724 mm
Weight	41 kg
m ³	0.02
Packed Length	500 mm
Packed Depth	630 mm
Packed Height	870 mm
Packed Weight	50 kg
Capacity	1000 Glass/Hour
Total Power	3.2 Kw
Basket Dimension	400x400 mm